



Specification of: REM 11-0225-2W-07

High performance Centrifugal fan Gebhardt rotavent with external HIGH EFFICIENCY motor in efficiency class IE 2 (IEC 60034-30)

single inlet with direct drive. Lap-jointed scroll housing made from galvanised steel sheet, without pedestal for vertical or horizontal mounting. centrifugal impeller with 11 backward curved blades, degreased, ironphoshated and painted Motor B5, mounted outside the airstream. Impeller and shaft statically and dynamically balanced in accordance with DIN ISO 21940-11, completely maintenance free. The motor is equipped with PTC Thermistors as a standard. Three phase 400 V, 50 Hz, single speed.

Technical data of the fan: REM 11-0225-2W-07

fulfills the ErP requirements 2015

Description	Value	Dimension
Specified duty point		
Air flow rate (V)	1811	m ³ /h
Static pressure rise (dp _{ra})	10	Pa
Actual duty point		
Installation acc. DIN 24163 Part 1	A	
Reference density (Rho1)	1.20	kg/m ³
Medium temperature (t)	20	C
Air flow rate (V)	1823	m ³ /h
Total pressure rise (dp _t)	157	Pa
Dynamic pressure at discharge (pd ₂)	147	Pa
Static pressure increase (dp _{ra})	10	Pa
fan speed (n _v)	-	min ⁻¹
Absorbed power (P ₁)	0.373	kW
Current (I)	-	A
Total system efficiency (ETA _{ts})	-	%
Static system efficiency (ETA _{raS})	-	%
Specific Fan Power (SFP-factor)	-	W/(m ³ /s)
Fan Efficiency Grade (FEG-factor)		
Nozzle calibration factor (K ₁₀)	58	m ² /s/h
Differential pressure on nozzle (dp _D)	593	Pa
Velocity at discharge area (c)	15.6	m/s
Fan weight	11	kg
A-weighted sound power level discharge/intake LwA _{4/7}	82/82	dB
Unweighted octave sound power level	Octave mid frequencies ¹⁾ 63/125/250/500/1k/2k/4k/8k Hz 88/83/80/80/76/74/68/53 dB discharge LwOkt ₄ 70/75/76/80/78/74/69/58 dB intake LwOkt ₇	

¹⁾ The octave sound power levels can be higher at octave bands at or close to blade passing frequency.

Rated data

Phase-Voltage-Frequency	3~230/400-50	V-Hz
Frame size-poles:	71 M / IE2-2	
Motor rating (P _N)	0.37	kW
Rated motor speed (n _N)	2770	min ⁻¹
Rated motor current (I _N)	1,65/0,95	A
Capacitor (C)	-	µF

operational limits

Max. absorbed power (P _{1max})	-	kW
Max. fan speed (n _{vmax})	-	min ⁻¹
Max. operating frequency (f _{max})	-	Hz
Temperature range of conveying medium (t _{min} ... t _{max})	-20...60	C

ErP-Data at best efficiency and density 1.20 kg/m³

measurement- / efficiency category	B / total	
design status of VSD	without VSD	
overall efficiency (ETA _{opt})	51.2	%
achieved efficiency grade (N _{ist})	66.5	
required efficiency grade in 2013 / 2015 (N)	61 / 64	
Air flow rate (V _{opt})	987	m ³ /h
pressure rise (dp _{opt})	646	Pa

Fan speed (n_{vopt})	2864 min ⁻¹
motor power input (P_{1opt})	0.346 kW
specific ratio (d_{dopt})	1.006

Fan curve to REM 11-0225-2W-07

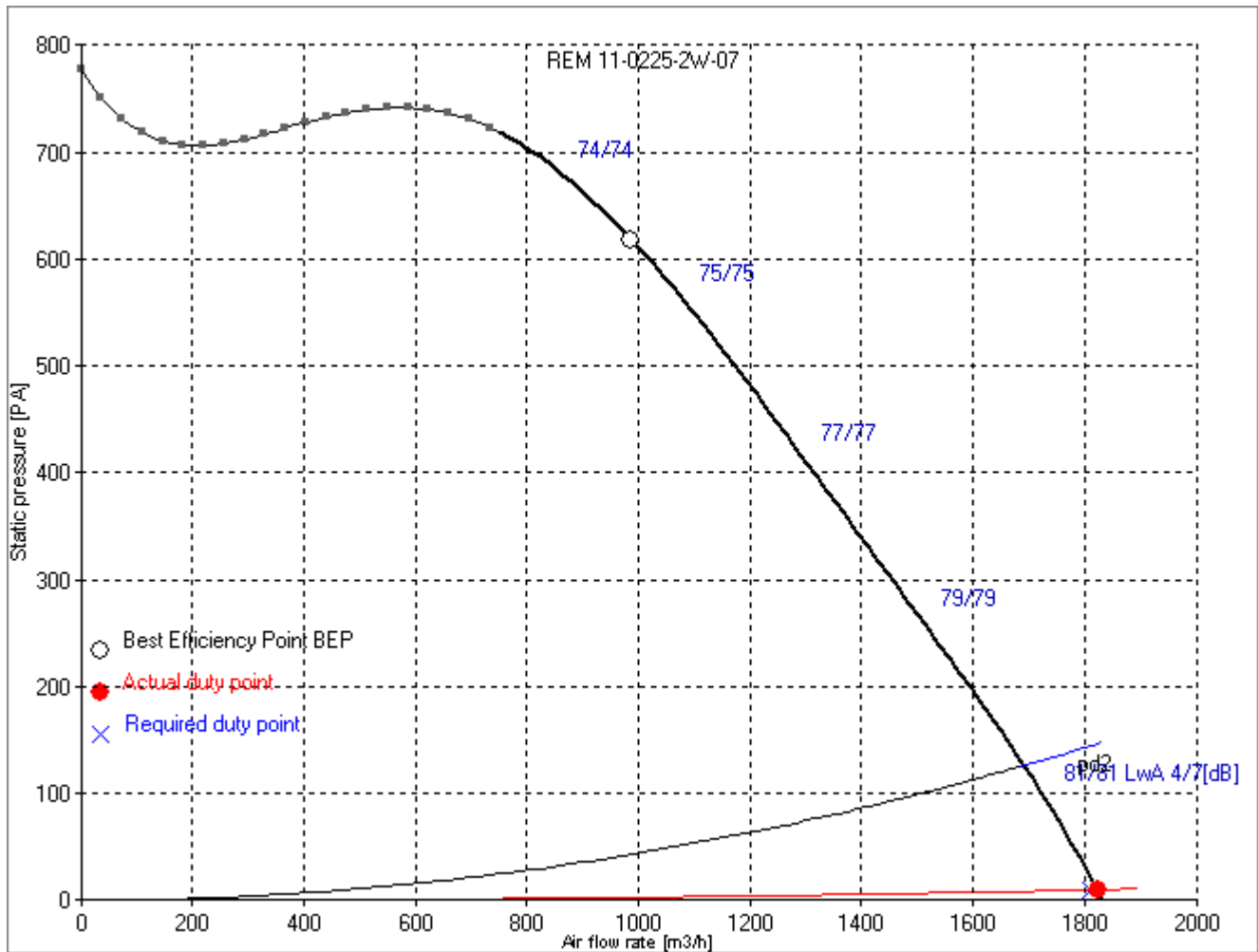

Dimensions to REM 11-0225-2W-07

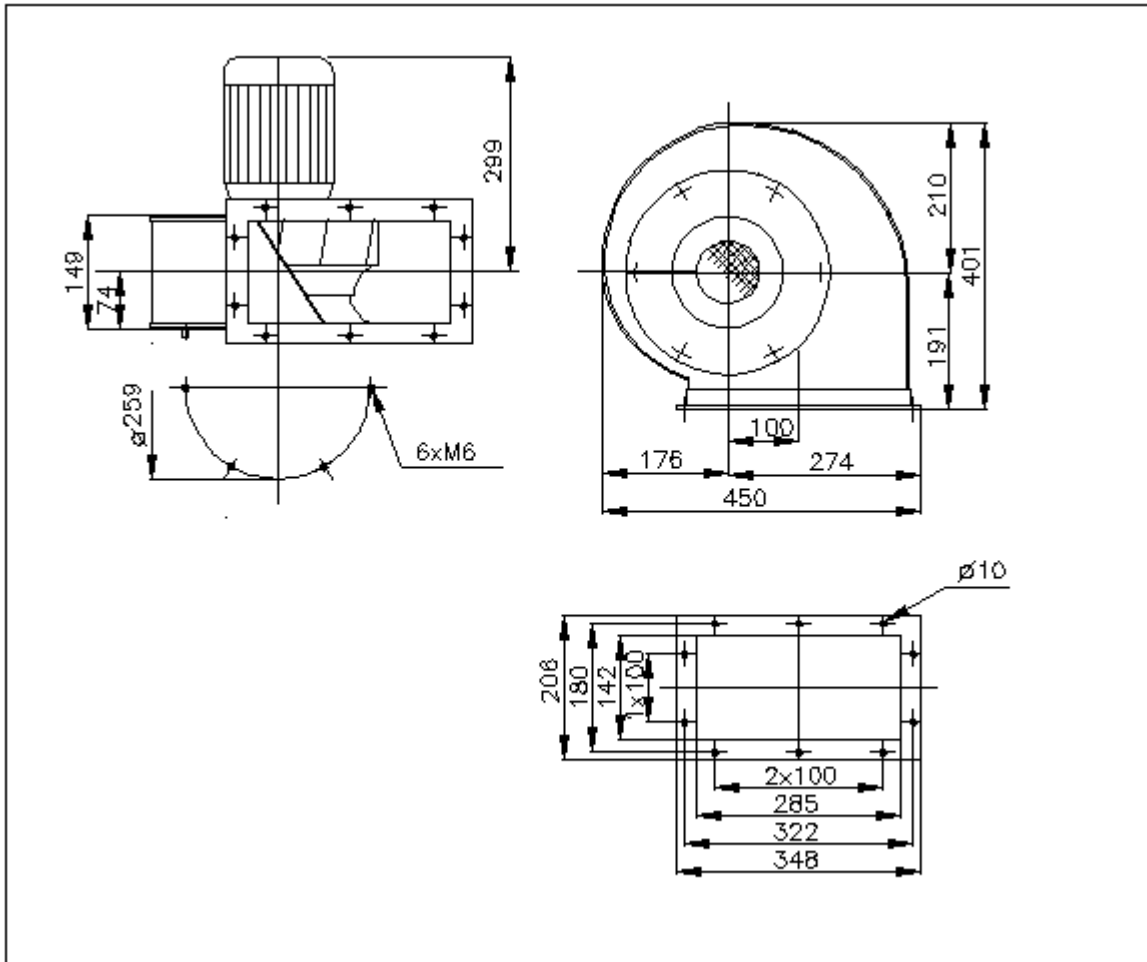

Rotation:
Handing:

RD
90